

HEAT METERS

Wall-mounted calculator

- MID Approved
- BMS output
- Pulsed output [Kw/hr], M-bus or 4-20mA versions
- Dn 15-300 applications
- Battery or 230v AC versions
- IP65 protection rating
- EMC Class C according to EN1434
- Measurement range: 1 - 150°C
- Ambient temperature: 5 - 55°C
- Temperature resolution: 0.01°C
- Measuring frequency: 20 - 120 seconds
- No data loss when battery removed
- PT500 sensors
- For use with Mechanical, Ultrasonic or Magflow meters
- Two pulsed inputs available as standard



Delta Flowtech



Temperature sensor pockets:
1/2" BSP X 85mm

TECHNICAL DATA

Part No.	Power source	Pulse output values	
		Energy [Kwh per pulse]	Volume [m³ per pulse]
DHM PIPO-1L	Battery 3v Li	1	0.1
DHM PIPO-10L	Battery 3v Li	10	0.1
DHM PIPO-100L	Battery 3v Li	100	1
DHM PIPO-1000L	Battery 3v Li	100	1
DHM PIPO230VAC-1L	230v AC 50Hz	1	0.1
DHM PIPO230VAC-10L	230v AC 50Hz	10	0.1
DHM PIPO230VAC-100L	230v AC 50Hz	100	0.1
DHM PIPO230VAC-1000L	230v AC 50Hz	100	1

ADDITIONAL FEATURES

- Continuous display of the accumulated heat energy on a large LCD display
- Application-oriented display menu; easy to scan using operating key
- Data storage six times a day in non-volatile memory
- Hourly self-check
- 12 monthly values readable on the display or via the optional interface
- Available lengths of temperature sensors: **3m [2-wire type] and 10m [4-wire type]**
- Installation in temperature pockets of various lengths possible.

Electrical characteristics

Switching current	150mA~/-
Switching voltage	75mA/-
Switching power	5vA
Contact resistance [contact open]	10 ¹⁰ ohm
Contact capacity	≤ 0.6 pF
Maximum current [contact closed]	1A
Max. voltage [open contact]	140v~/-
Pulse duration [contact closed]	100ms
Minimum time between pulses	400ms
Bounce time	0.5ms

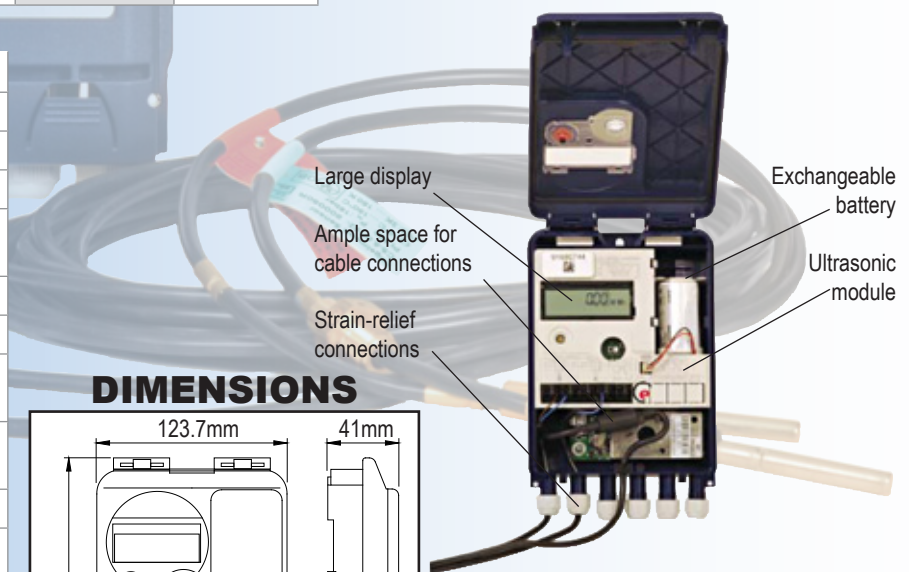

DIMENSIONS

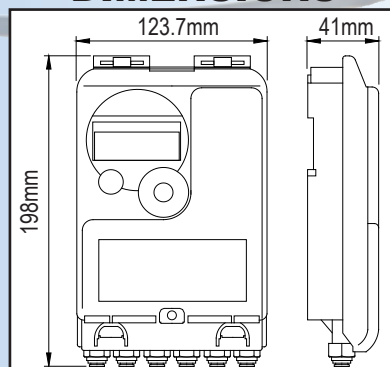

Delta Flowtech

Tel: 0845 862 5553 | Fax: 0845 862 5554 | Email: info@deltaflowtech.com | W: www.deltaflowtech.com



THE MENU

The large high contrast display continuously shows the accumulated heat energy. This enables an easy, sure and quick read-out of the most commonly needed figures.

1. Level / Main Loop



1) Total heat energy / Total cooling energy –standard display– (alternating display without pressing the button heat/cooling meters)



2) Segment test, all triggered simultaneously.

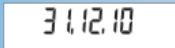

3) Total heat energy / cooling energy at last billing date alternating with that date.¹⁾ Flow volume, tariff values, or the values of the individual pulse counters can be shown if this has been set.



4) Total volume in m³

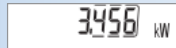

5) Current power in kW



6) Current flow in m³/h



7) Current date



8) Error message (alternating binary and hexadecimal display)

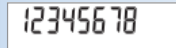

9) Selectable customer-set calculator no. (secondary address); factory setting is the serial no.



10) Tariff register 1: Values alternating with tariff register and criteria.²⁾³⁾

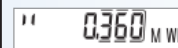

11) Tariff register 2: Values alternating with tariff register and criteria.²⁾³⁾



12) Momentary reading of the pulse counter 1 alternating with the pulse value.²⁾³⁾

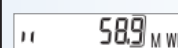

13) Momentary reading of the pulse counter 2 alternating with the pulse value.²⁾³⁾

2. Level / Technician's Loop



1) Current forward flow temperature in C°



2) Current return flow temperature in C°



3) Temperature difference in C°



4) Days since first verification of calculator



5) Pulse value of calculator



6) M-bus address (primary address)

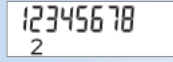

7) Serial number



8) Software / firmware version



9) Return flow or Forward flow Temperature sensor type and mounting position



10) Set billing date

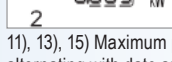

11), 13), 15) Maximum power value alternating with date and time of occurrence.



12), 14), 16) Maximum flow value alternating with date and time of occurrence.

3. Level / Statistics Loop



Previous billing date alternating with its values. Alternatively, the total volume, tariff values, or values of individual instruments connected to the optional pulse inputs can be displayed, if so set.¹⁾



2-16) 15 Monthly values: Dates alternating with their values. Alternatively, the total volume, tariff values, or the values of individual pulse counters can be displayed, if so set.¹⁾

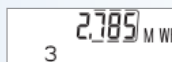

¹⁾ Up to the end of the month the consumption and billing date for that month will be shown as 0.
²⁾ Can be set using the Monitor software. A dedicated meter password is necessary. Password available from manufacturer.
³⁾ Note: For invoicing, the total heat energy must be used.

Products and specifications may be subject to change from those shown without notice.

HEAT METERS

Wall-mounted calculator



Delta Flowtech

STORAGE INSTRUCTIONS

Dry and frost protected

INSTALLATION INSTRUCTIONS

- Loosen a cable gland and slide it over the cable. Remove the blind plug in the cable gland opening.
- Feed the pulse cable of the flow meter through the opening into the terminal box.
- Clamp on the wires as shown in the illustration.

Note: For flow meters with open collector connections (electronic outputs) make sure the polarity is correct.



Connection of flow meter

- Check that the connections are tight.
- Screw the cable glands tight by hand.

CONNECTION OF OPTIONAL INTERFACES

- The following are options that the calculator can be equipped with at the factory (state when ordering) and will vary depending on the individual calculator.
- Feed the cable to be connected (cable diameter 3.5 to 6.5mm) through an opening on the bottom edge of the calculator housing into the space containing the terminal strips.
- The terminal clamps are designed to fit strands with ends with a cross-section of 0.5 – 1.5 mm².
- Clamp on the cable according to the following illustrations that apply depending on the interface.

Connection of M-bus

Polarity is not important for these connections, so the wires can be clamped arbitrarily.

When the M-bus network is in operation a triangle will appear in the lower right corner of the display. (Power supply from M-bus network is functioning.)

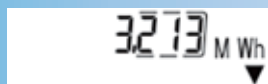

Important:

Please check the unused cable glands to make sure that the necessary blind plugs are inserted and then tighten the cable glands by hand.

Connection of pulse outputs or inputs

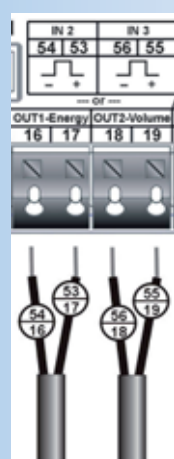

Depending on the option, there are two additional pulse inputs located here (IN) for further meters or two pulse outputs (OUT) for connection to an additional system.

For connection of meters with open collectors attention must be paid to the polarity.

MOUNTING

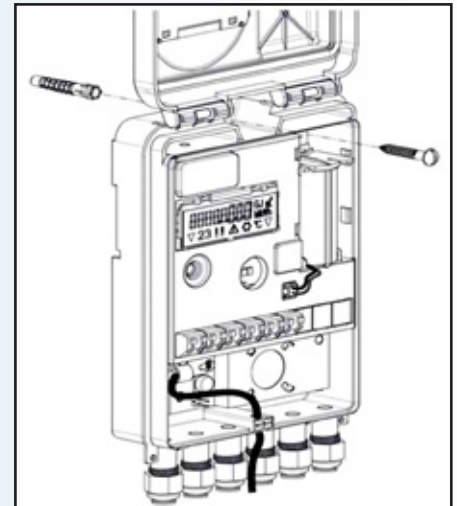

PULSE VALUE

Display format according to pulsed input value.

Pulse l/imp	Energy [MWh]	Volume [m ³]	Flow [m ³ /hr]	Power [kW]
1	0.000	0.000	0.000	0.000
10	0.00	0.00	0.00	0.00
100	0.0	0.0	0.0	0.0
1000	0	0	0	0

Connection of mains power pack

Only use a Sensor power pack supplied by us. Any alternative device will invalidate the warranty and may cause technical issues.

It is imperative to pay attention to the polarity.

Check that the connections are tight.

- The power pack should only be connected to 230V and checked by authorized technical personnel.
- Check on the display whether a triangle appears in the lower right corner, as shown in the illustration.
- Screw the cable gland tight by hand.
- Close the cover of the calculator housing and protect against unauthorized opening.

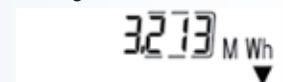

All sizes are approximate and are given for guidance only.

Products and specifications may be subject to change from those shown without notice.

03/12

Delta Flowtech

Tel: 0845 862 5553 | Fax: 0845 862 5554 | Email: info@deltaflowtech.com | W: www.deltaflowtech.com